

# STEELCRAFT®

## FE16 AND FE14-SERIES FLUSH FRAMES

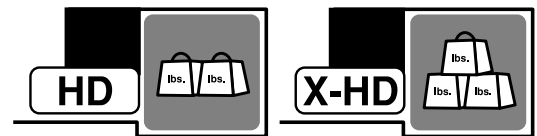

### ABOUT THE PRODUCT:

The FE16 and FE14-Series Double Egress Frames are designed for heavy and extra-heavy duty applications in both commercial and institutional buildings. They are installed in interior locations, and in virtually all types of buildings and wall constructions. These frames can be specified and/or supplied as either KD (knock-down) for field assembly prior to installation, or SUA (set-up and welded) for installation as a pre-welded unit.

### APPLICATIONS:

The FE-Series Double Egress Frames are designed to separate corridors into fire areas. When the assembly is fully installed, it incorporates a pair of doors swinging in opposite directions. The doors line up in the centerline of the frame. A center mullion is not required.

The standard jamb profile of the standard FE-Series Double Egress Frame reduces the corridor width by a total of 5¼" (133mm), and does not allow the use of swing clear hinges. This must be considered if your code has a minimum clear opening width requirement.

The FE-Series Double Egress Frames are typically used in the following types of wall constructions:

Wall Construction	Application	Typical Wall Anchors
Masonry	wrap or butted	Wire masonry
Existing masonry	butted	Bolted through soffit
Wood stud	wrap	Weld-in wood stud anchor
Steel stud	wrap	Weld-in steel stud anchor

Steel Thickness	Opening	Usage Frequency <sup>1</sup>	Applications
14 gage (1.7mm)	Interior & Exterior	Extra-heavy to Maximum duty	<ul style="list-style-type: none"> <li>16 &amp; 14 gage steel doors</li> </ul>
16 gage (1.3mm)	Interior & Exterior	Heavy to Extra-heavy duty	<ul style="list-style-type: none"> <li>20, 18 &amp; 16 gage steel doors</li> <li>Commercial grade wood doors</li> </ul>
Steel Type	Opening	Applications	
Non Galvanneal <sup>3</sup>	Interior	<ul style="list-style-type: none"> <li>Typical building conditions</li> </ul>	
Galvannealed <sup>2</sup>	Interior	<ul style="list-style-type: none"> <li>Used in locations with high humidity</li> </ul>	

### MATERIAL:

FE-Series Double Egress Frames are supplied from either 14 gage (1.7mm) or 16 gage (1.3mm) steel. Depending on environmental and usage conditions, the steel can be either non galvanneal or galvannealed. All frames are supplied with a factory applied baked on primer for field applied finish paints.

### FEATURES AND BENEFITS:

Steelcraft's FE-Series Double Egress Frames offer the following unique features, which enhance long term functionality and durability.

- Die-mitered corner connections (head/jamb)**  
Standard corners insure attractive, tight and closed miters.
- Patented universal hinge preparations** allow for easy field conversion from standard weight (.134) hinges to heavy weight (.180) hinges.
- Adjustable base anchors** allow for installation adjustment when the floor is not level.
- Rubber silencers** are factory installed.
- Factory applied baked on rust inhibiting primer** in accordance with ANSI A250.10.

### SPECIFICATION COMPLIANCE:

- Overall frame construction for the Steelcraft FE-Series Double Egress Frames meet and exceed the requirements of ANSI A250.8-1998 (commonly referred to as SDI-100).
- Hardware preparations and reinforcements are in accordance with ANSI A250.6-1997. Locations are in accordance with ANSI/DHI A115.

### FIRE RATINGS:

The FE-Series Double Egress Frames meet fire rating requirements. They are listed for installations requiring compliance to both negative pressure testing (ASTM E152 and UL-10B) and positive pressure standards (UBC 7-2 and UL-10C). Refer to the "Fire Rated" section of the Steelcraft Spec Manual for particular listings.

DOUBLE EGRESS FRAMES

Details are subject to change without prior notice.

© 2000 Steelcraft Co.  
Printed in USA

**IR** Security & Safety  
Proven Source. Proven Solutions.™

Spec Manual  
Rev. 5/2002

FE1-1

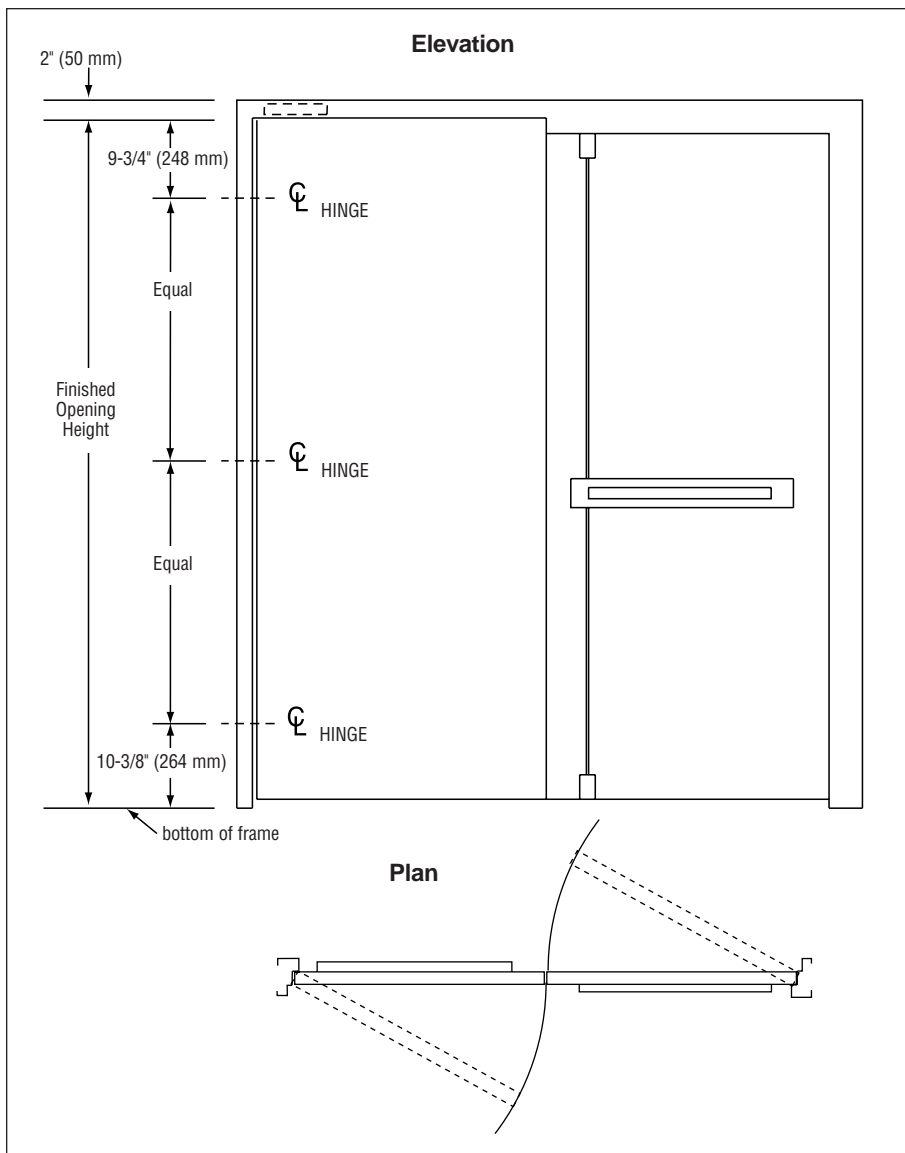

### CONSTRUCTION NOTES:

1. **Door opening size maximum:**  
Double door opening size 8'0" x 10'0"  
(2438mm x 3048mm)
2. **Jamb depths (profile) availability:**  
minimum = non label 4<sup>3</sup>/<sub>4</sub>" (121mm)  
= label 5<sup>3</sup>/<sub>4</sub>" (146mm)  
maximum = 14" (356mm)
3. **Standard profile dimensions (variations available):**  
Face = 2" (50mm)  
Stop = 5/8" (16mm)  
Returns = 1/2" (13mm) all frames  
except 5<sup>3</sup>/<sub>4</sub>" (146mm) which  
is 7/16" (11mm)
4. **Standard die-mitered corners:**  
Four (4) concealed tabs interlock head  
and jambs.

### NOTE:

Net width of head is 1/8" undersized from nominal.  
(e.g. 6'0" head=72" nominal and 71<sup>7</sup>/<sub>8</sub>" net width)

**DOUBLE EGRESS FRAMES**

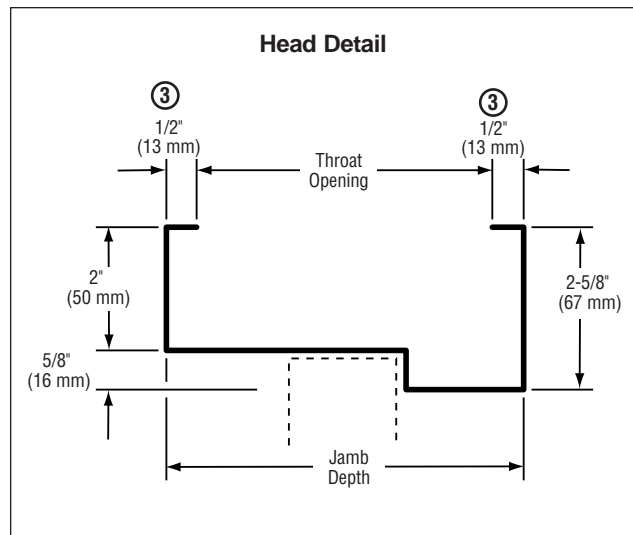
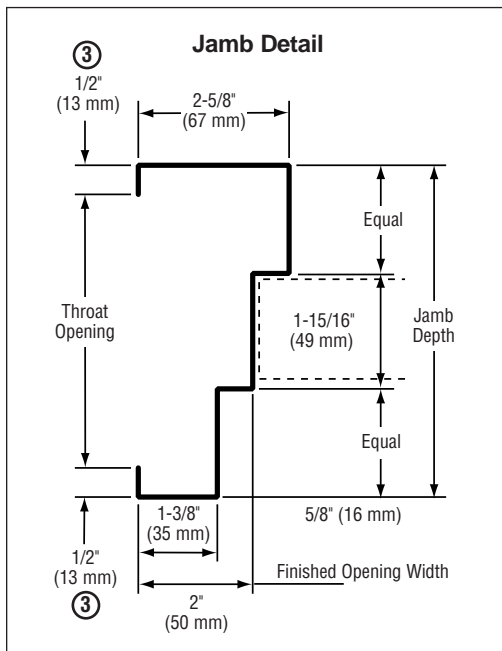

## Knock-Down Corner

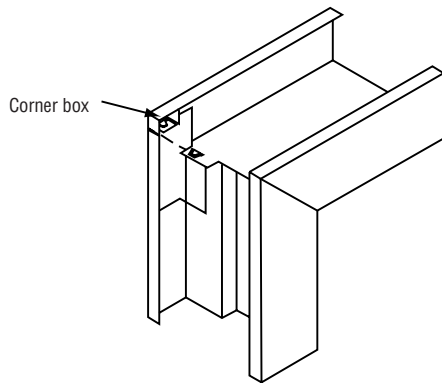

## Welded (SUA) Corner

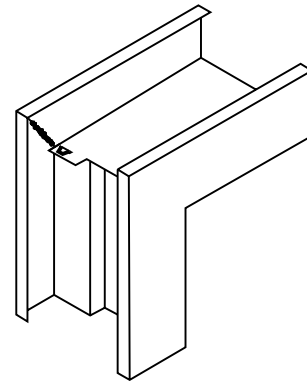

## Universal Mortise Hinge Prep

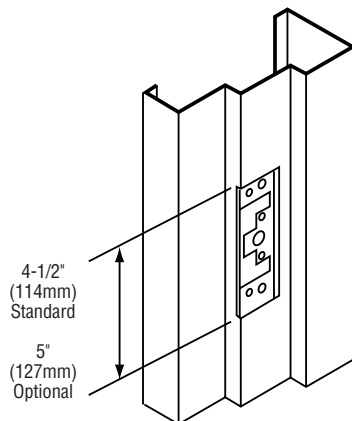

7 Gage Hinge Reinforcement

## GENERAL NOTES:

- Frame profile** – variations in jamb depths available in 1/8" (3mm) increments.
- Corner connections:**
  - **KD (knock-down)** – factory die-mitered.
  - **SUA (set-up and welded)** – available when specified, and in accordance with ANSI A250.8-1998 (SDI-100).
- Standard hardware preparations:** Standard mortised and reinforced with mortar guards for:
  - **Universal Hinge Preps** – 4 1/2" (114mm) patented preparation which allows easy and quick conversion from standard to heavy weight hinges.
- Rubber silencers** are factory installed to cushion the closing of the door and to eliminate the field problems related to inserting silencers after installation and grouting. Two (2) per head.

## Rubber Silencer

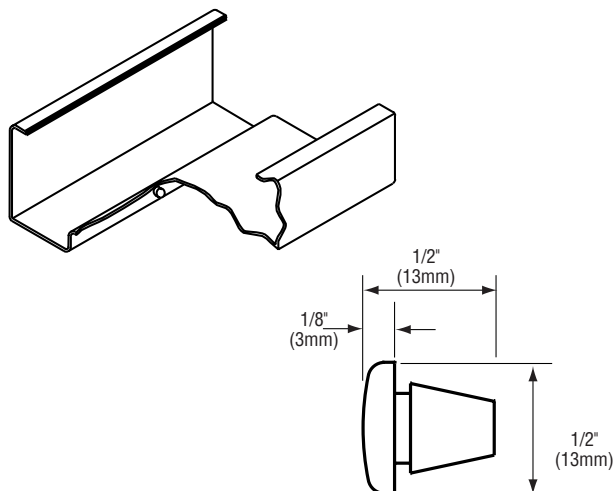

Wire Masonry Anchor

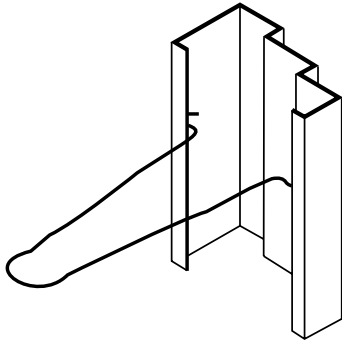

Existing Masonry Anchor

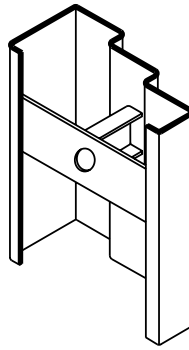

Adjustable Base

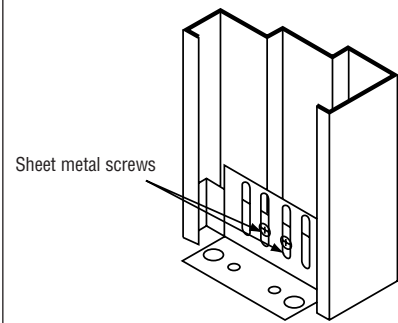

Anchor for Stud Partitions

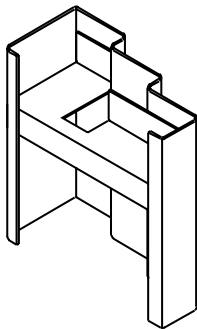

## ANCHORING AND INSTALLATION NOTES:

1. **FE-Series Double Egress Frames** are supplied standard with masonry wire, or weld-in jamb anchors and adjustable base anchors. Anchors are designed for maximum wall/frame engagement, and installation flexibility.
2. **Anchoring applications:**
  - **Masonry wall** – Masonry wire ( $\frac{3}{16}$ " [5mm] diameter) jamb anchors provide maximum engagements in mortar joints, and allow for full internal grouting during installation. Adjustable base anchors are attached directly to the floor and adjusted. The wall is built around the frame. (Refer to installation sheet #INS-2004)
  - **Existing masonry walls (EMA)** – Specifically designed (18 Ga. steel) jamb anchors are used to add support for bolting the frame into the rough opening of an existing wall. An existing wall anchor is used as the base anchor in this application. (Refer to installation sheet #INS-2014)
  - **Wood stud walls** – Weld-in (18 Ga. steel) jamb anchors are designed to be attached to the wood studs of a rough opening. After the frame is anchored, the wallboard is installed and finished. (Refer to installation sheet #INS-2005)
  - **Steel stud walls** – Weld-in (18 Ga. steel) jamb anchors are designed to be attached to the webbing of the closed steel studs which are built around the frame. Adjustable base anchors are attached directly to the floor and adjusted. After frame is anchored, the wallboard is installed and finished. (Refer to installation sheets #INS-2006 and 2007)
3. **Installation caution notice:** When temperature conditions necessitate an additive to be used in the plaster or mortar to prevent freezing, the contractor installing the frames shall coat the inside of the frames in the field with a corrosion resistant coating per SDI 105.
4. **Special frame anchorage:** Frame anchor details shown on this sheet are applicable to Double Egress Frames with 2" (50mm) faces. Anchor details will vary with frame profile changes.
5. Installation shall conform to the published Steelcraft installation instructions, SDI 105 *Recommended Installation Instructions for Steel Frames* and ANSI/DHI A115-IG *Installation Guide for Doors and Hardware*.
6. All fire rated frames must be installed in accordance with NFPA Pamphlet 80 and the *Authority Having Jurisdiction*.