

# STEELCRAFT®

## CE-SERIES DOORS WITH DUAL VISION LITES (Maximum 1/2" Thick Glass)

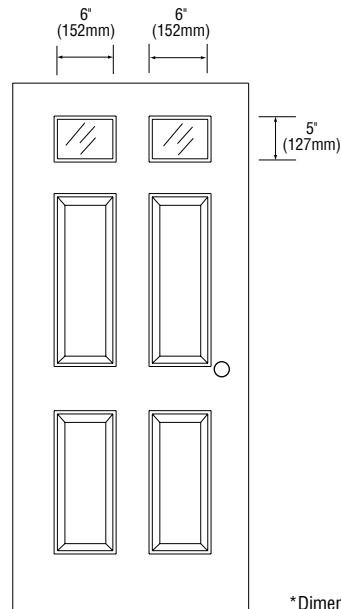

E23

\*Dimensions are shown to the Exposed Glass Size

### DUAL VISION DOOR LITES:

Designation for a door with two glass lites located in the top section of the door face.

### GLAZING BEAD SYSTEM:

1/4" (6mm) thick glass lites are available as standard with the Steelcraft Designer® trim system.

1/2" (13mm) thick insulated glass lites, are available as an option with the Steelcraft Designer trim system for insulated glass.

### GLASS LITE SIZES:

The following critical dimensions apply to the standard E23 (individual) dual vision lite window design:

Window Widths	Door Widths			
	2'8"	3'0"	3'4"	3'6"
EGS =	6"	6"	6"	6"
GCS =	7 1/8"	7 1/8"	7 1/8"	7 1/8"
DCS =	7 19/32"	7 19/32"	7 19/32"	7 19/32"

Window Heights	Door Heights		
	6'8"	6'10"	7'0"
ECS =	5"	5"	5"
GCS =	6 1/8"	6 1/8"	6 1/8"
DCS =	6 19/32"	6 19/32"	6 19/32"

Note: EGS = Exposed Glass Size  
GCS = Glass Cutting Size  
DCS = Door Cutout Size

### GLAZING DETAILS:

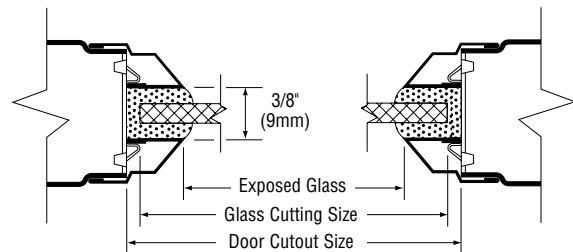

EMBOSSED DOOR LITES

Details are subject to change without prior notice.

© 2000 Steelcraft Co.  
Printed in USA

**IR Security & Safety®**

Spec Manual  
Effective 3/00

**GLE2**