

STEELCRAFT®

VON DUPRIN INPACT™ GLASS LITES (Mortise and Concealed Vertical Rod)

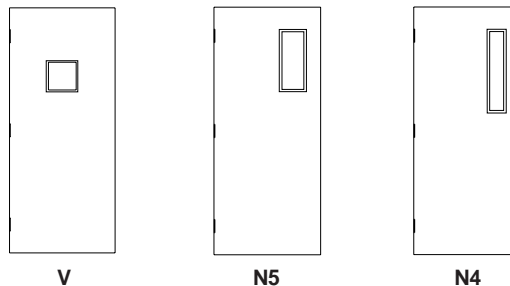
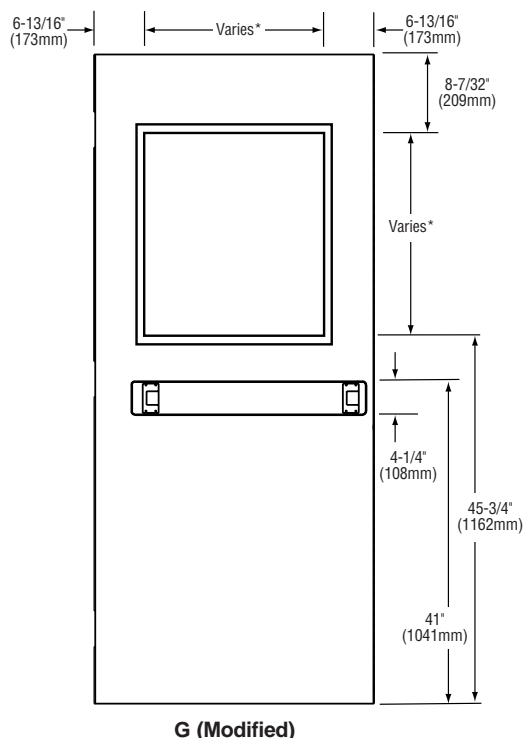

*Dimensions are shown to the Exposed Glass

GLASS LITES:

Glass lite cutouts are available in N4, N5 and V-Lite designs without modification. Other lites are available but have limited height due to the exit device preparation.

GLAZING BEAD SYSTEM:

1/4" (6mm) thick glass lites are available as standard with the Steelcraft Dezigner® Series trim system.

1/2" (13mm) thick insulated glass lites, are available as an option with the Steelcraft Dezigner Series trim system for insulated glass.

Insulated glass lites thicker than 1/2" (13mm) are available as an option with specially designed overlapping steel trim.

GLASS LITE SIZES:

The following dimensions outline the maximum glass heights available with the INPACT door preparation:

| Door Heights* (Nominal) | 6'8" | 7'0" | 7'2" | 8'0" |
|------------------------------|---------|---------|---------|---------|
| Maximum Exposed Glass Height | 25 1/8" | 29 1/8" | 31 1/8" | 41 1/8" |

*To determine maximum glass lite height for other sized doors, for exposed glass, subtract 54" (1372mm) from net door size.

The following critical dimension applies to the standard Steelcraft lite designs with INPACT preparation:

Glass Cutting Size = exposed glass size + 1 1/8"
Door Cutout Size = exposed glass size + 1 1/2"

GLAZING DETAILS:

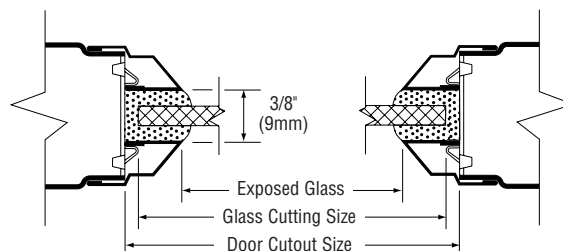

NOTES:

1. Consult code for ADA requirements on glass cutouts.
2. Refer to Spec sheets **H6-5** and **H6-6** (Hardware section) for specific INPACT device preparation requirements.

Details are subject to change without prior notice.

© 2000 Steelcraft Co.
 Printed in USA

IR Security & Safety
 Proven Source. Proven Solutions.™

Spec Manual
 Rev. 5/2002

GLS-1

SPECIAL GLASS LITES