

# STEELCRAFT®

## HARDWARE PREPARATIONS – STRIKES

### ANSI A 115.1 AND A115.2 (4<sup>7</sup>/<sub>8</sub>" [124mm]) STRIKES

Typical Preparation

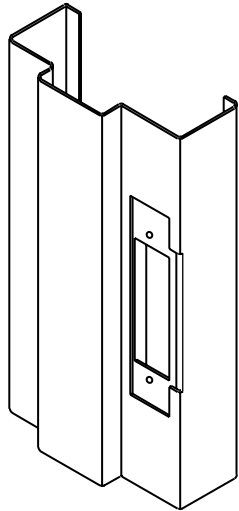

Reinforcement

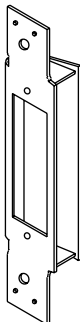

16 Gage  
Strike Reinforcement

#### GENERAL INFORMATION:

The ANSI A115.1 and ANSI A115.2 strikes are designed to function with the ANSI A115.1 and 115.2 locks and mortise exit devices. Some mortise and bored-in deadlocks will function with these strikes.

#### DESCRIPTION:

ANSI A115.1 and ANSI A115.2 strikes are 4<sup>7</sup>/<sub>8</sub>" (124mm) high and 1<sup>1</sup>/<sub>4</sub>" (32 mm) wide. The centerline of the strike is located 40<sup>5</sup>/<sub>6</sub>" (1024 mm) from the bottom of the frame. This location will function with the ANSI A115.1 and A115.2 locks and the mortise exit devices. The location for deadbolts must be adjusted (normally 48" [1219 mm] from the bottom of the frame) to match the deadlock being used. The centerline of the strike is located 1<sup>5</sup>/<sub>6</sub>" (24 mm) from the stop of the strike jamb.

The normal lip on the strike is 1<sup>1</sup>/<sub>4</sub>" (32 mm). This allows the strike lip to extend beyond the frame face providing a guide for the latch bolt. The lip is omitted on deadlock strikes.

#### REINFORCEMENT:

The reinforcement used is a specially formed 16-gage steel part and is projection welded to the door rabbet of the strike jamb. The special formed reinforcement includes extruded attaching holes to provide adequate threads for the strike plate screws. The reinforcement includes a dust (mortar) box that is deep enough to receive the 1" (25 mm) throw latch bolt or deadbolt.

#### TEMPLATE:

Lock manufacturers template should be reviewed carefully to insure the strike being used will function in the preparation. Although Steelcraft's preparation meets or exceeds the ANSI standard, some manufacturer's strikes may not fit properly in the cutout or provide enough lip extension.

#### SPECIFICATION COMPLIANCE:

The ANSI A115.1 and ANSI A115.2 strike preparation meets or exceeds the requirements of the Steel Door Institute (SDI) and the Door and Hardware Institute (DHI).

#### FIRE RATINGS:

The ANSI A115.1 and ANSI A115.2 strikes can be used in fire rated frames with ratings from 20 minute to 3 hours.

**Note:** 1. Doors are not supplied with the locks or the locks installed.

**IR** Security & Safety®  
Proven Source. Proven Solutions.™

Details are subject to change without prior notice.

© 2000 Steelcraft Co.  
Printed in USA

Spec Manual  
Rev. 5/2002

H8-1

STRIKES

**ANSI A115.1 AND A115.2 (4<sup>7</sup>/<sub>8</sub>" [124mm]) STRIKE WITH ASTRAGAL**

**Typical Preparation**

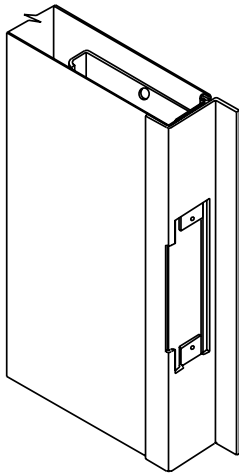

**Reinforcement**

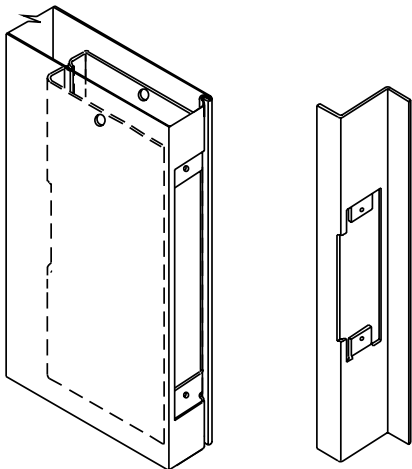

14 Gage (1.7mm) Astragal with Integral Mounting Tabs

**GENERAL INFORMATION**

The ANSI A115.1 and ANSI A115.2 strikes are designed to function with the ANSI A115.1 and 115.2 locks and mortise exit devices. Some mortise and bored-in deadlocks will function with these strikes.

**DESCRIPTION:**

ANSI A115.1 and ANSI A115.2 strikes are 4<sup>7</sup>/<sub>8</sub>" (124mm) high and 1<sup>1</sup>/<sub>4</sub>" (32 mm) wide. The centerline of the strike is located 39<sup>9</sup>/<sub>16</sub>" (1005 mm) from the bottom of the door. This location will function with the ANSI A115.1 and A115.2 locks and the mortise exit devices. The location for deadbolts must be adjusted (normally 47<sup>1</sup>/<sub>4</sub>" [1199 mm] from the bottom of the frame) to match the deadlock being used. The centerline of the strike is located in the center of the door edge.

**REINFORCEMENT:**

The astragal is cut and offset (formed) to provide tabs to which the strike plate is attached. The tabs are drilled and tapped for the attaching screws. The special formed reinforcement provides adequate threads for the strike plate screws. The reinforcement is projection welded to the door panel.

**TEMPLATE:**

Lock manufacturers template should be reviewed carefully to insure the strike being used will function in the preparation. Although Steelcraft's preparation meets or exceeds the ANSI standard, some manufacturer's strikes may not fit properly in the cutout or provide enough lip extension.

**SPECIFICATION COMPLIANCE:**

The ANSI A115.1 and ANSI A115.2 strike preparation meets or exceeds the requirements of the Steel Door Institute (SDI) and the Door and Hardware Institute (DHI).

**FIRE RATINGS:**

The ANSI A115.1 and ANSI A115.2 strikes when used with an astragal can be used on openings with ratings from 20 minutes to 3 hours.

**Note:** 1. Doors are not supplied with the strike plate or the strike plate installed.

## ANSI A115.1 AND A115.2 (4<sup>7</sup>/<sub>8</sub>" [124mm]) STRIKE WITHOUT ASTRAGAL

Typical Preparation

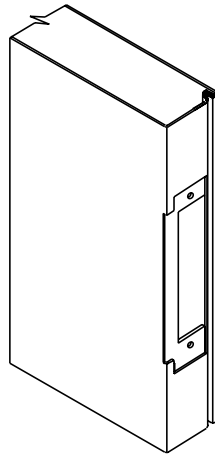

Reinforcement

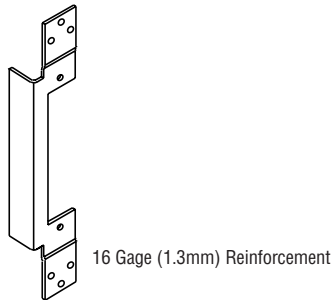

### GENERAL INFORMATION:

The ANSI A115.1 and ANSI A115.2 strikes are designed to function with the ANSI A115.1 and 115.2 locks and mortise exit devices. Some mortise and bored-in deadlocks will function with these strikes.

### DESCRIPTION:

ANSI A115.1 and ANSI A115.2 strikes are 4<sup>7</sup>/<sub>8</sub>" (124mm) high and 1<sup>1</sup>/<sub>4</sub>" (32 mm) wide. The centerline of the strike is located 39<sup>9</sup>/<sub>16</sub>" (1005 mm) from the bottom of the door. This location will function with the ANSI A115.1 and A115.2 locks and the mortise exit devices. The location for deadbolts must be adjusted (normally 47<sup>1</sup>/<sub>4</sub>" [1199 mm] from the bottom of the frame) to match the deadlock being used. The centerline of the strike is located in the center of the door edge.

The normal lip on the strike is 1<sup>1</sup>/<sub>4</sub>" (32 mm). This allows the strike lip to extend beyond the frame face providing a guide for the latch bolt. The lip is omitted on deadlock strikes.

### REINFORCEMENT:

The reinforcement used is a specially formed 16-gage steel part and is projection welded to the door edge. The special formed reinforcement provides adequate threads for the strike plate screws. The reinforcement is projection welded to the door panel.

### TEMPLATE:

Lock manufacturers template should be reviewed carefully to insure the strike being used will function in the preparation. Although Steelcraft's preparation meets or exceeds the ANSI standard, some manufacturer's strikes may not fit properly in the cutout or provide enough lip extension.

### SPECIFICATION COMPLIANCE:

The ANSI A115.1 and ANSI A115.2 strike preparation meets or exceeds the requirements of the Steel Door Institute (SDI) and the Door and Hardware Institute (DHI).

### FIRE RATINGS:

The ANSI A115.1 and ANSI A115.2 strikes when used without an astragal is limited to openings rated 1<sup>1</sup>/<sub>2</sub> hour and less.

**Note:** 1. Doors are not supplied with the strike plate or the strike plate installed.

## ANSI A115.3 (2¾" [70mm]) STRIKE

Typical Preparation

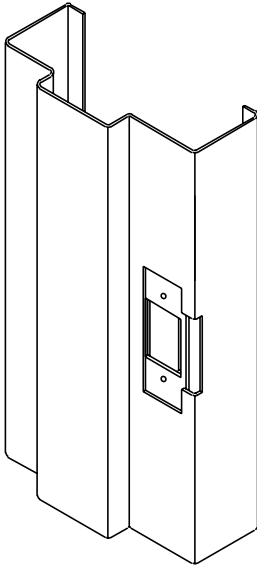

Reinforcement

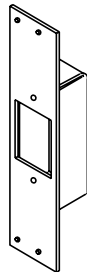

14 Gage (1.7mm) Reinforcement

### GENERAL INFORMATION:

The ANSI A115.3 strike is designed to function with the ANSI A115.2 and 115.3 locks and bored-in deadlocks.

### DESCRIPTION:

ANSI A115.3 strike is 2¾" (70mm) high and 1⅛" (28 mm) wide. The centerline of the strike is located 40⅝" (1024 mm) from the bottom of the frame. This location will function with the ANSI A115.2 and A115.3 locks. The location must be adjusted (normally 48" [1219 mm] from the bottom of the frame to match the deadlock being used. The centerline of the strike is located 1⅝" (24 mm) from the stop of the strike jamb

The normal lip on the strike is 1¼" (32 mm). This allows the strike lip to extend beyond the frame face providing a guide for the latch bolt. The lip is omitted on deadlock strikes.

### REINFORCEMENT:

The reinforcement used is a 14-gage steel part and is projection welded to the frame rabbet. The reinforcement includes extruded attaching holes to provide adequate threads for the strike plate screws. The reinforcement includes a dust (mortar) box welded to the reinforcement that is deep enough to receive the 1" (25 mm) throw latch bolt or deadbolt.

### TEMPLATE:

Lock manufacturers template should be reviewed carefully to insure the strike being used will function in the preparation. Although Steelcraft's preparation meets or exceeds the ANSI standard, some manufacturer's strikes may not fit properly in the cutout or provide enough lip extension.

### SPECIFICATION COMPLIANCE:

The ANSI A115.3 strike preparation meets or exceeds the requirements of the Steel Door Institute (SDI) and the Door and Hardware Institute (DHI).

### FIRE RATINGS:

The ANSI A115.3 strike can be used in fire rated frames with ratings from 20 minute to 3 hours.

**Note:** 1. Frames are not supplied with the strike plate or the strike plate installed.

## ROLLER LATCH STRIKE

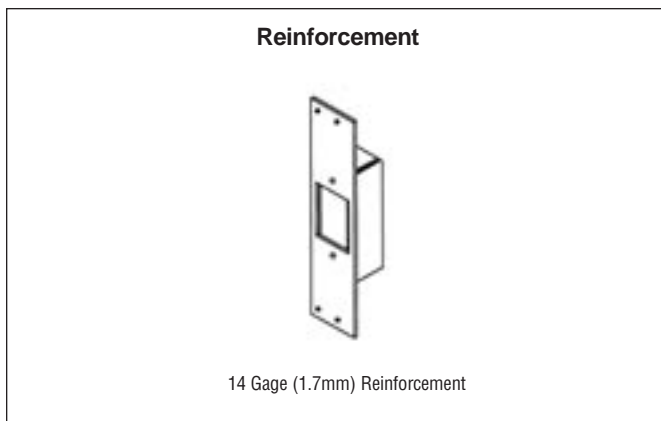
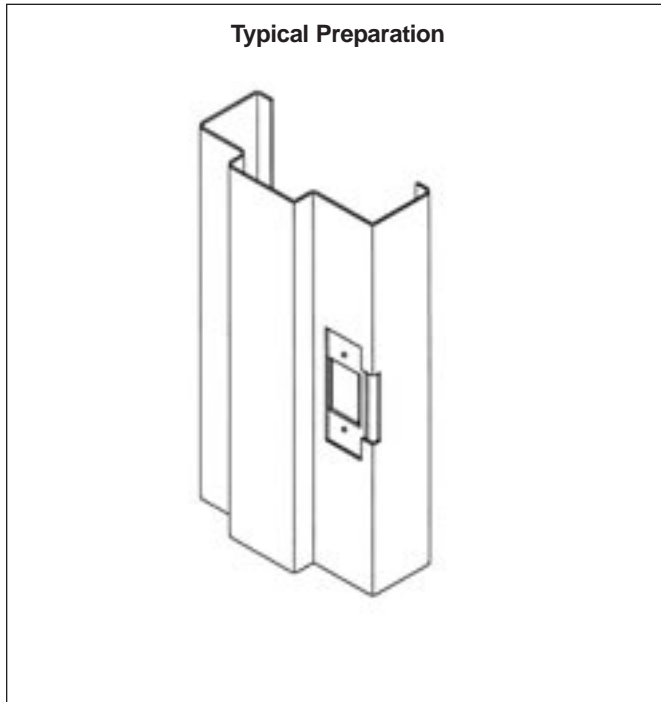

### GENERAL INFORMATION:

Roller latches are used to hold doors in position without the use of a latch bolt. The roller latch is spring loaded and holds the door in position by tension.

### DESCRIPTION:

Roller latch strikes are similar to the ANSI A115.3 strike. In some cases the roller latch strike will function in the A115.3 cutout. Some strikes although similar require a smaller cutout or will require a full lip type (lip same width as the strike) cutout.

The strike can be located in the strike jamb (single openings) or in the frame header (double doors).

### REINFORCEMENT:

The reinforcement used is a 14-gage steel part and is projection welded to the frame strike jamb (single openings) or to the frame header (double openings). The reinforcement provides adequate threads for the strike plate screws. The reinforcement includes a dust (mortar) box welded to the reinforcement.

### TEMPLATE:

Roller Latch manufacturers template should be reviewed carefully to insure the strike being used will function in the preparation.

### SPECIFICATION COMPLIANCE:

The Roller Latch strike preparation meets or exceeds the requirements of the Steel Door Institute (SDI) and the Door and Hardware Institute (DHI).

### FIRE RATINGS:

Roller latches cannot be used in fire rated openings. Roller latches have not been tested and do not meet the definition of self-latching mechanisms.

**Note:** 1. Doors are not supplied with the locks or the locks installed.

**OPEN BACK STRIKE – FOR MORTISE EXIT DEVICES**

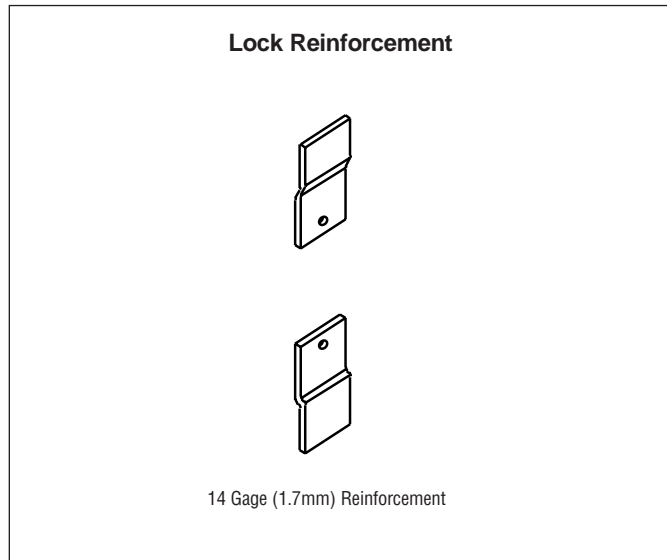
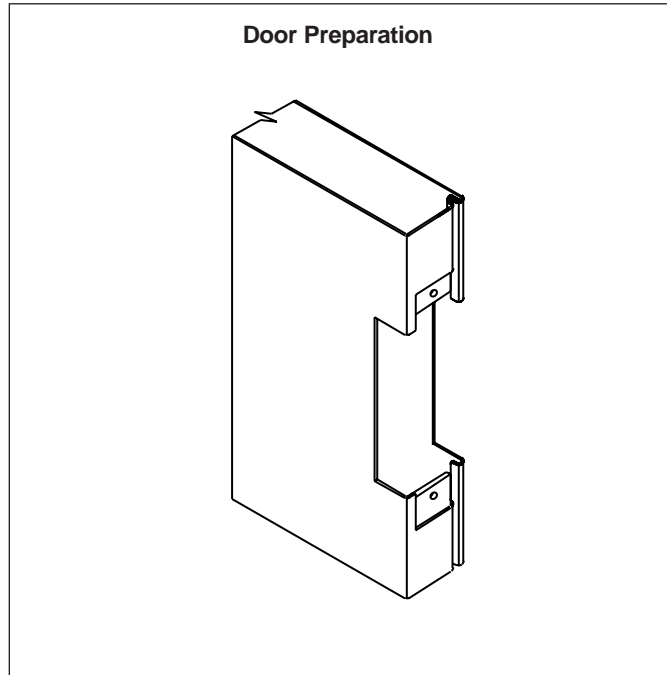

**GENERAL INFORMATION:**

Open back strikes are used in the in-active leaf of a pair of doors when mortise and vertical rod exit devices are used. The use of the open back strike allows the in-active leaf to open and close without affecting the active leaf

The term "open back" strike is derived from the fact that the back (push side of the door opening) of the strike is open. The latch bolt of the mortise exit device is held in position since the front of the open back strike is closed the same as a normal strike.

**DESCRIPTION:**

The preparation includes a cutout that is made in the edge of the in-active door leaf. The preparation includes the necessary reinforcements for the attachment of the strike. The strike preparation is located per the exit device manufacturer's template so that it will align with the mortise exit device latch bolt.

The inactive leaf also includes the necessary preparation for a surface or concealed vertical rod exit device.

**REINFORCEMENT:**

The preparation consists of a 14-gage steel reinforcement of such design to function properly with the open back strike. The reinforcement(s) is drilled and tapped at the factory for the strike screws. The reinforcement is welded to the door edge and in some cases to the door face.

**TEMPLATE:**

Open back strike manufacturers template should be reviewed carefully for preparation required in door edge.

**SPECIFICATION COMPLIANCE:**

The ANSI A115.14 open back strike preparation meets or exceeds the requirements of the Steel Door Institute (SDI) and the Door and Hardware Institute (DHI).

**FIRE RATINGS:**

The open back strike preparation can be used in the in-active leaf of fire rated doors. The active leaf must incorporate a mortise exit device and the in-active leaf a surface or concealed vertical rod exit device. Open back strikes are limited in fire rated doors with ratings of 20 minutes, ¾ and 1½ hours. An Astragal cannot be used with open back strikes.

**Notes:** 1. Doors are not supplied with the open back strikes or the strike installed.

## RIM EXIT DEVICE STRIKE – SURFACE MOUNTED

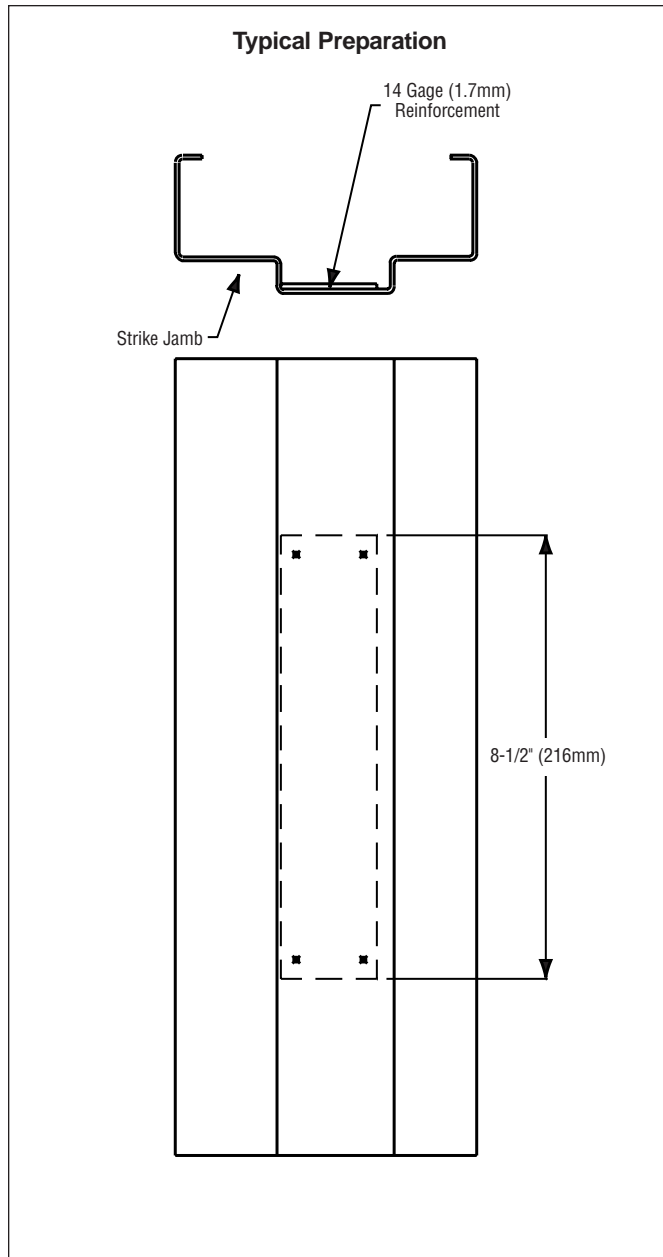

### GENERAL INFORMATION:

Steelcraft's rim exit device strike preparation is designed to function with all rim exit devices.

### DESCRIPTION:

The preparation is designed to accept the surface mounted strike supplied by the exit device manufacturer. The frame is reinforced only and all drilling and tapping is done in the field by others.

The centerline of the preparation is located per the exit device manufacturer's template.

### REINFORCEMENT:

The preparation consists of a 14-gage steel plate 8½" (216 mm) long by minimum 2" (950 mm) wide, welded to the soffit of the strike jamb. The plate is held to the door side of the jamb. A dust (mortar) box is not provided.

### TEMPLATE:

Exit device manufacturers template should be reviewed.

### SPECIFICATION COMPLIANCE:

The rim exit device strike preparation meets or exceeds the requirements of the Steel Door Institute (SDI) and the Door and Hardware Institute (DHI).

### FIRE RATINGS:

The rim exit device strike preparation can be used in fire rated frames with ratings from 20 minute to 3 hours.

**Note:** 1. Frames are not supplied with the panic device strike or with the panic device strike installed.

**SURFACE VERTICAL ROD EXIT DEVICE STRIKE – SURFACE MOUNTED**

**Typical Preparation**

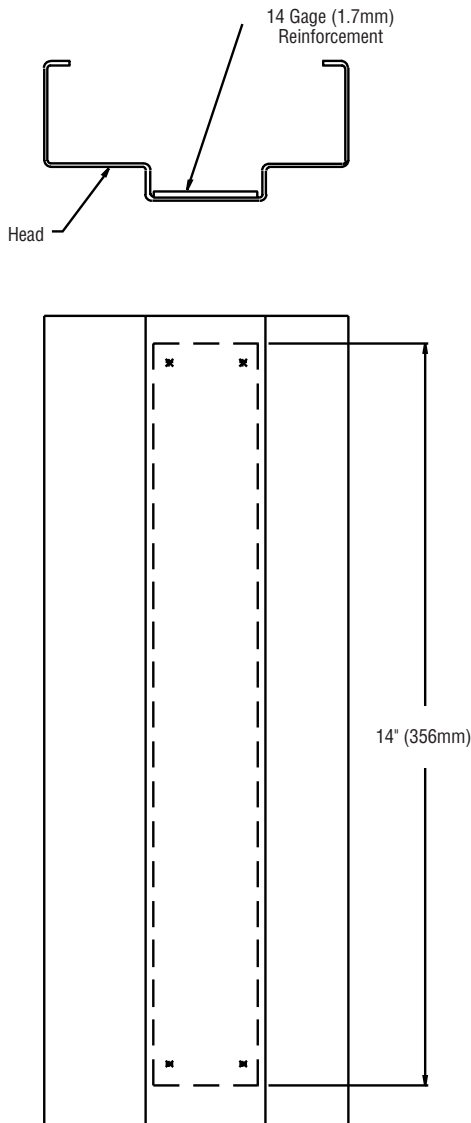

**GENERAL INFORMATION:**

Steelcraft's vertical rod exit device strike preparation is designed to function with all vertical rod exit devices.

**DESCRIPTION:**

The preparation is designed to accept the surface mounted strike supplied by the exit device manufacturer. The head of the frame is reinforced only and all drilling and tapping is done in the field by others.

The preparation is located in the soffit area and in the center of the frame head.

**REINFORCEMENT:**

The preparation consists of a 14-gage steel plate 14" (356 mm) long by 2" (50 mm) wide, welded to the soffit of the frame header. The plate is held to the door side of the jamb. A dust (mortar) box is not provided.

**TEMPLATE:**

Exit device manufacturers template should be reviewed carefully to insure the strike being used will function in the preparation.

**SPECIFICATION COMPLIANCE:**

The vertical rod exit device strike preparation meets or exceeds the requirements of the Steel Door Institute (SDI) and the Door and Hardware Institute (DHI).

**FIRE RATINGS:**

The vertical rod exit device strike preparation can be used in fire rated frames with ratings from 20 minute to 3 hours.

- Notes:**
1. Doors are not supplied with the open back strikes or the strike installed.
  2. Open back strikes can be used in non-rated doors.

## CONCEALED VERTICAL ROD EXIT DEVICE STRIKE – MORTISE TYPE

Typical Mortised Strike Preparation in Head

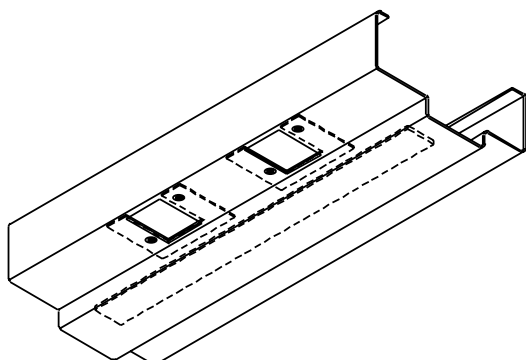

Typical Strike Reinforcement

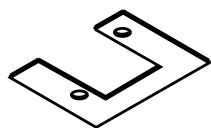

14 Gage (1.7mm) Reinforcement

### GENERAL INFORMATION:

Steelcraft's concealed vertical rod exit device strike preparation is made per the manufacturer's template.

### DESCRIPTION:

The preparation is designed to accept the mortise type strike supplied by the exit device manufacturer. The head of the frame is cutout and reinforced for the strikes. The reinforcements are drilled and tapped for the mounting screws.

The preparation is located in the door rabbet of the frame header and is located to match the concealed exit devices being used in the doors.

### REINFORCEMENT:

The preparation consists of a 14-gage steel plate of such design to function properly with the exit device strike. The reinforcements are welded to the door rabbet of the frame header. A dust (mortar) box is provided.

### TEMPLATE:

Exit device manufacturers template should be reviewed carefully to insure the strike being used will function in the preparation:

### SPECIFICATION COMPLIANCE:

The concealed vertical rod exit device strike preparation meets or exceeds the requirements of the Steel Door Institute (SDI) and the Door and Hardware Institute (DHI).

### FIRE RATINGS:

The concealed vertical rod exit device strike preparations are used on fire rated frames for double doors only. They are limited to fire rated frames with ratings of 20 minutes, ¾ and 1½-hour. Double egress up to 3 hours.

**Note:** 1. Frames are not shipped with the strike plates or strike plates installed.

**FLUSH BOLT STRIKE – MORTISE TYPE**

**Typical Flush Bolt Strike Preparation**

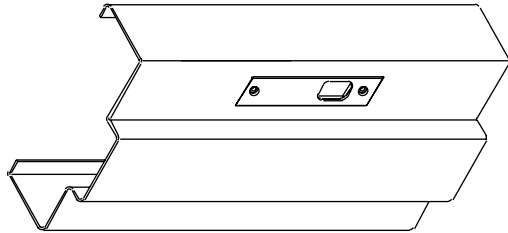

**Lock Reinforcement**

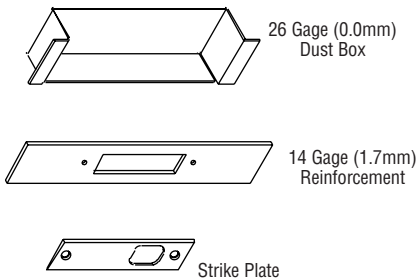

**GENERAL INFORMATION:**

Steelcraft's flush bolt strike preparation is designed to be non-handed. The preparation includes a cutout, reinforcement and strike plate that will function with all flush bolts.

**DESCRIPTION:**

The preparation includes a cutout located in the door rabbet of the frame header that is large enough to cover both right hand and left hand active openings. A reinforcing plate that is offset to accept a reversible strike/filler is welded into the door rabbet of the frame header. A prime painted strike/filler plate is supplied installed. To change hands it is necessary to remove the strike/filler plate and reinstall for the other hand using the same strike/filler plate and screws.

**PREPARATION:**

**Reinforcement:** the preparation consists of a 14-gage steel plate of such design to function properly with the flush bolt. The reinforcement is drilled and tapped at the factory. The reinforcements are welded to the door rabbet of the frame header. A dust (mortar) box is provided.

**Strike Plate:** preparation includes a universal prime painted strike plate with attaching screws.

**TEMPLATE:**

Flush bolt manufacturers template should be reviewed carefully to insure the bolt being used will function in the preparation.

**SPECIFICATION COMPLIANCE:**

The flush bolt strike preparation meets or exceeds the requirements of the Steel Door Institute (SDI) and the Door and Hardware Institute (DHI).

**FIRE RATINGS:**

The flush bolt strike preparation can be used for the in-active leaf of fire rated frames that are not a required means of egress. They can be used in fire rated frames with ratings of 20 minutes,  $\frac{3}{4}$ ,  $1\frac{1}{2}$  and 3 hours.

- Notes:**
1. The flush bolt strike/filler plate is prime painted and installed at the factory for right hand openings.
  2. For left hand openings, remove the plate and reinstall as required.

## DEADLOCK STRIKE

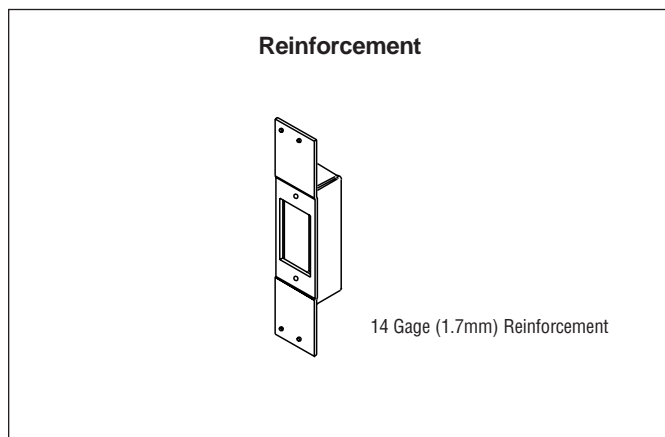
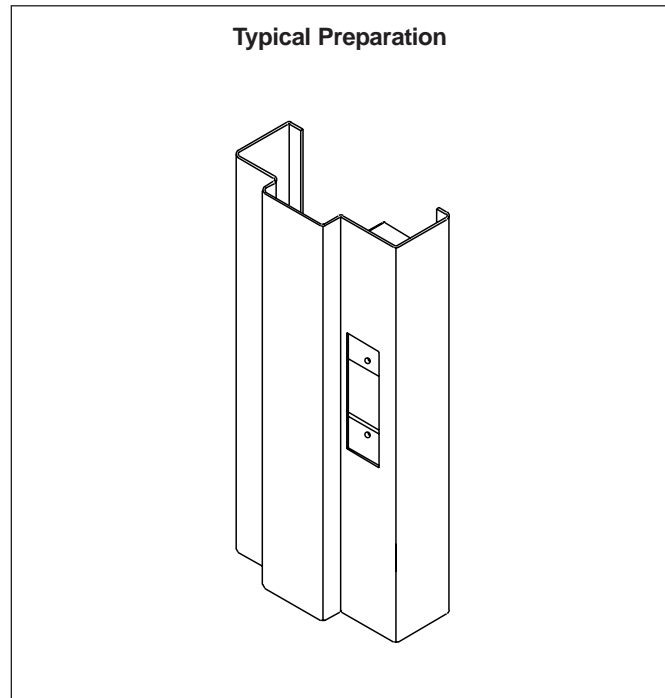

### GENERAL INFORMATION:

Deadlock strikes are normally rectangular shaped non-lip type strikes that are designed to work with bored-in or mortise deadlocks. A lip strike can be used if the cutout for the deadbolt is located properly and is the correct size.

### DESCRIPTION:

The deadlock strike preparation is a rectangular shaped cutout in the door rabbet of the strike jamb. The centerline of the deadlock strike is located 48" (1219 mm) from the bottom of the frame and the door preparation adjusted to match the strike.

### REINFORCEMENT:

The reinforcement used is a formed 14-gage steel plate that is welded to the door rabbet of the strike jamb. The reinforcement provides adequate threads for the strike plate screws. In addition the reinforcement includes a dust (mortar) box that is deep enough to receive the 1" (25 mm) throw deadbolt.

### TEMPLATE:

Deadlock strike manufacturers template should be reviewed carefully for the preparation required in the frame.

### SPECIFICATION COMPLIANCE:

The deadlock strike preparation meets or exceeds the requirements of the Steel Door Institute (SDI) and the Door and Hardware Institute (DHI).

### FIRE RATINGS:

Deadlocks can be used in fire rated openings with 20 minute, ¾, 1½ and 3 hour ratings provided they are:

1. used in addition to an approved self latching mechanism.
2. used in an opening that is not a required means of egress.

**Note:** 1. Frames are supplied with strike plate or with strike plate installed.

**EMERGENCY RELEASES**

**Typical Release Mechanism Preparation**

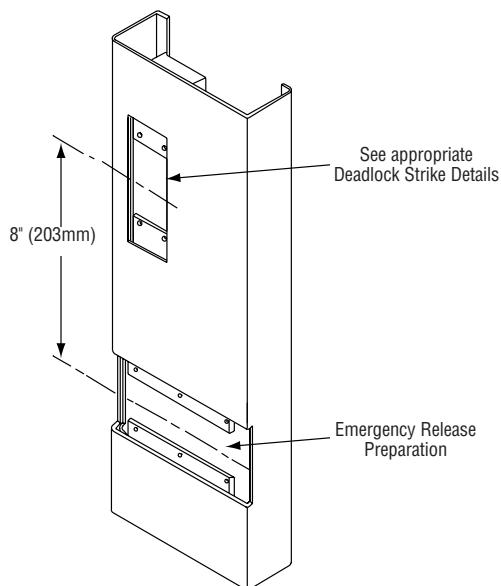

**Reinforcement**

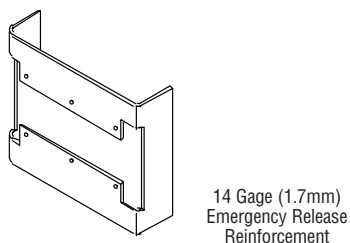

**GENERAL INFORMATION:**

Emergency Releases are design to permit the opening of a door when a body is lying against the door. It is used in nursing homes, hospitals and other places where emergency door operation is required.

**DESCRIPTION:**

The Emergency Release consists of a special designed mechanism that acts as a doorstop. In an emergency the mechanism can be released allowing the door to swing out of the opening. The release mechanism extends the full jamb depth width and can be surface mounted or mortised into the strike jamb. The centerline of the release mechanism is located 40<sup>5</sup>/<sub>16</sub>" (1024 mm) from the bottom of the frame.

Also included is a double acting pivot requiring a cased open frame. The pivot preparation in the door and frame are similar to the center hung pivot preparation shown on sheet H2-7.

**REINFORCEMENT:**

The reinforcement used is a formed 14-gage steel plate that is welded to the strike jamb. The reinforcement provides adequate threads for the release mechanism mounting screws. A dust (mortar) box is not included with the preparation.

**TEMPLATE:**

Emergency Release manufacturers template should be reviewed carefully for the preparation required in the frame.

**SPECIFICATION COMPLIANCE:**

The Emergency Release is not now covered by the Steel Door Institute (SDI) and the Door and Hardware Institute (DHI).

**FIRE RATINGS:**

Emergency Release Mechanism cannot be used in fire rated openings.

**Note:** 1. Frames are not supplied with the release/stop mechanism or release/stop mechanism installed.