



### ABOUT THE PRODUCT:

The MU18-Series Multi-Use Flush Frames are designed for light commercial applications. They are installed in interior locations, and in virtually all types of buildings and wall constructions. They have a jamb profile similar to the DW-Series Frames, but are designed to be installed as part of the wall framing sequence. They can be specified and/or supplied as KD (knock-down) for field assembly prior to installation.

### APPLICATIONS:

The MU-Series Multi-Use Flush Frames are typically used in the following types of wall constructions:

Wall Construction	Application	Typical Wall Anchors
Masonry	wrap or butted	Wire masonry
Existing masonry	butted	Bolted through soffit
Wood stud	wrap	Lock-in wood stud anchor
Steel stud	wrap	Lock-in steel stud anchor

Steel Thickness	Opening	Usage Frequency <sup>1</sup>	Applications
18 gage (1mm)	Interior	Light to Standard duty	<ul style="list-style-type: none"> <li>20 gage steel doors</li> <li>Hollow core wood doors</li> </ul>
Steel Type	Opening	Applications	
Non Galvanneal <sup>3</sup>	Interior	<ul style="list-style-type: none"> <li>Typical building conditions</li> </ul>	
Galvannealed <sup>2</sup>	Interior	<ul style="list-style-type: none"> <li>Used in locations with high humidity</li> </ul>	

### MATERIAL:

MU-Series Multi Use Flush Frames are supplied from 18 gage (1mm) steel. Depending on environmental and usage conditions, the steel can be either non galvanneal or galvannealed. All frames are supplied with a factory applied baked on primer for field applied finish paints.

### FEATURES AND BENEFITS:

Steelcraft's MU-Series Light Commercial Multi-Use Flush Frames offer the following unique features which enhance long term functionality and durability.

1. **Die-mitered connection** locks the jambs and head miters together once the frame is installed.
2. **Adjustable base anchors** allow for installation adjustment when the floor is not level.
3. **Rubber silencers** are factory installed.
4. **Factory applied baked on rust inhibiting primer** in accordance with ANSI A250.10.

### SPECIFICATION COMPLIANCE:

1. Overall frame construction for the Steelcraft MU-Series Multi-Use Flush Frames meet the requirements of ANSI A250.8-1998 (commonly referred to as SDI-100).
2. Hardware preparations and reinforcements are in accordance with ANSI A250.6-1997. Locations are in accordance with ANSI/DHI A115).

<sup>1</sup> Usage frequency is based on ANSI A250.8-1998

<sup>2</sup> Reinforcements for galvannealed frames are also galvannealed

<sup>3</sup> Commercial quality carbon steel

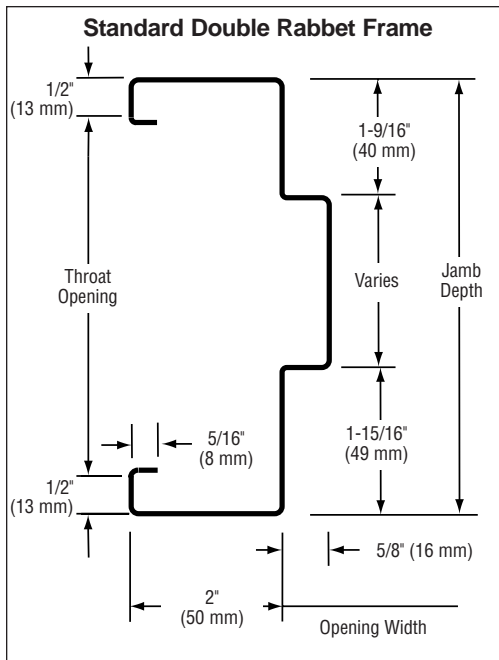
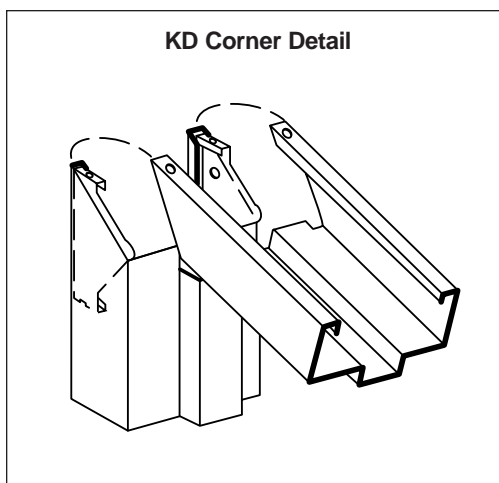
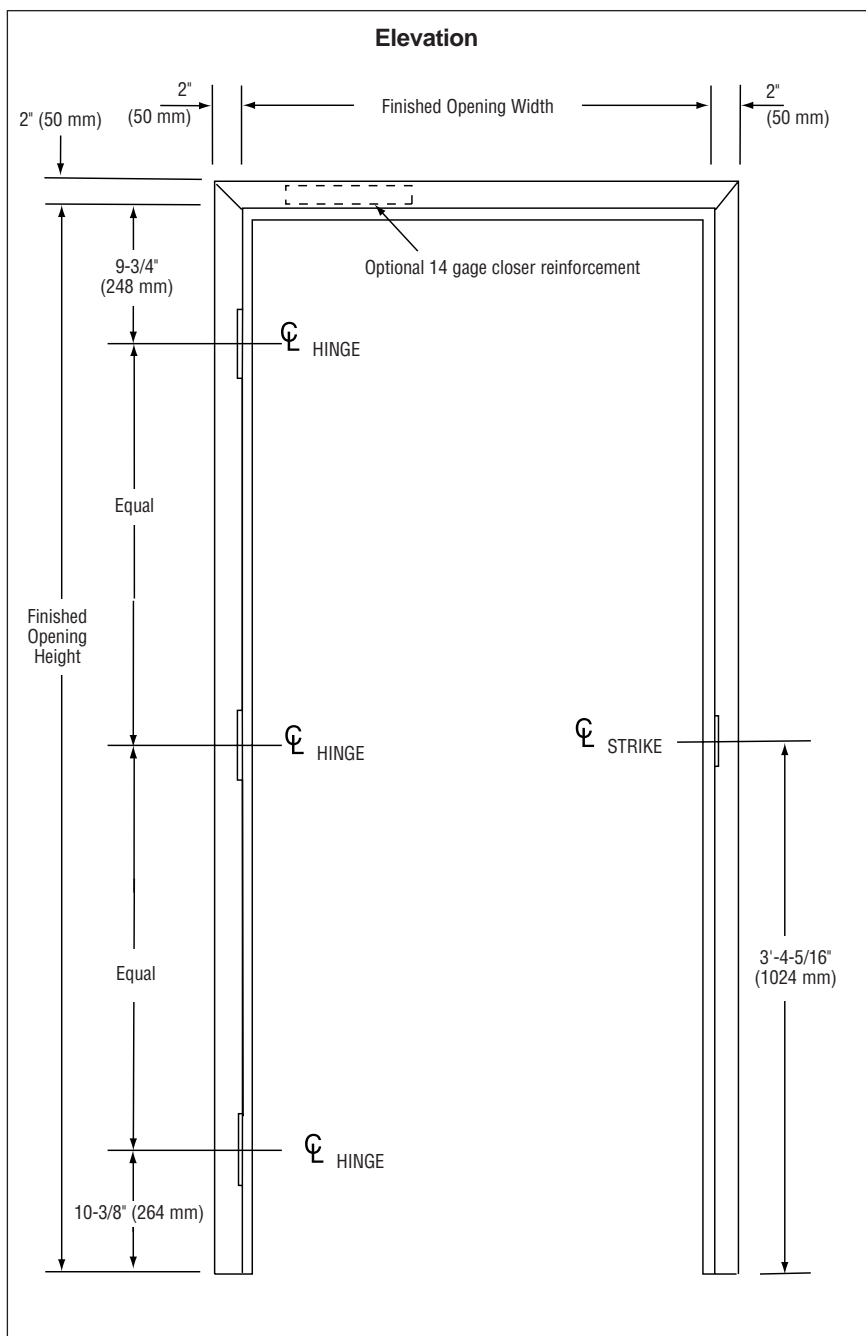

### CONSTRUCTION NOTES:

- Door opening size maximum:**  
 Single door opening size 4'0" x 8'0" (1219mm x 2438mm)  
 Double door opening size 8'0" x 8'0" (2438mm x 2438mm)
- Jamb depths (profile) availability:**  
**Double rabbet:**  
 minimum = 4<sup>3</sup>/<sub>4</sub>" (121mm)  
 maximum = 8<sup>1</sup>/<sub>4</sub>" (209mm)
- Standard profile dimensions (variations not available):**  
 Face = 2" (50mm)  
 Stop = 5/8" (16mm)  
 Returns = 1/2" (13mm) all frames except 5<sup>3</sup>/<sub>4</sub>" (146mm) which is 7/16" (11mm)
- Standard die-mitered corners:**  
 Include interlocking soffit tab and corner clip attachments.

### Mortise Hinge Prep

1¾" (45mm) doors

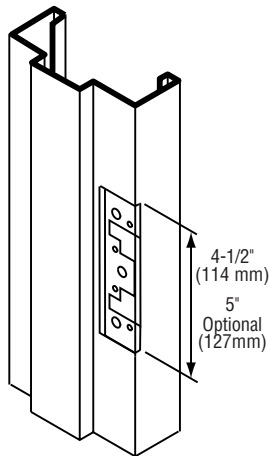

7 Gage Hinge Reinforcements

### Mortise Hinge Prep

1⅝" (35mm) doors

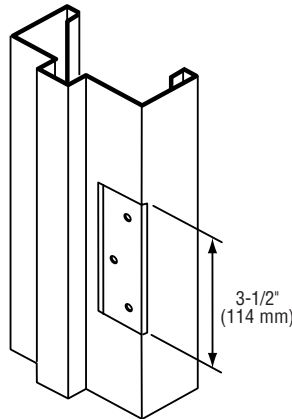

10 Gage Hinge Reinforcements

### 4⅞" Strike Prep (ASA)

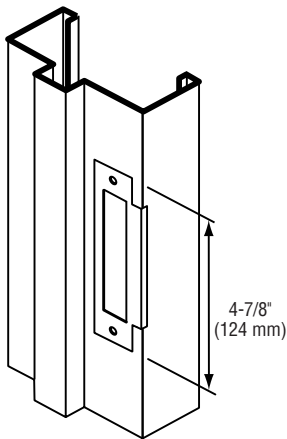

### 2¾" Strike Prep (CYL)

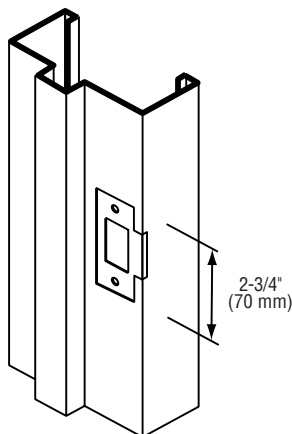

### Rubber Silencer

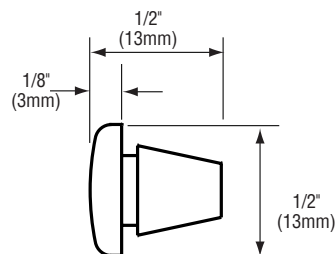
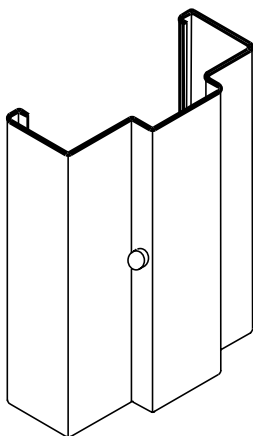

### GENERAL NOTES:

- Frame Profile** – variations in jamb depths available in ⅛" (3mm) increments:  
Double rabbet - typically for walls 3¾" (95mm) thick and over
- Corner connections:**
  - **KD (knock-down)** – factory die-mitered
  - **SUA (set-up and welded)** – not available in this frame series
- 4" (102mm) heads** – not available in this frame series
- Standard hardware preparations:**  
Standard mortised and reinforced with mortar guards for:
  - **Universal hinge preps** – 4½" (114mm) patented preparation
  - **Strikes** – 4⅞" (124mm) conforming to ANSI A115.1 and ANSI A115.2
- Rubber silencers** are factory installed to cushion the closing of the door, and to eliminate the field problems related to inserting silencers after installation and grouting. Three (3) silencers are supplied per strike jamb and two (2) per double door head.

**Wire Masonry Anchor**

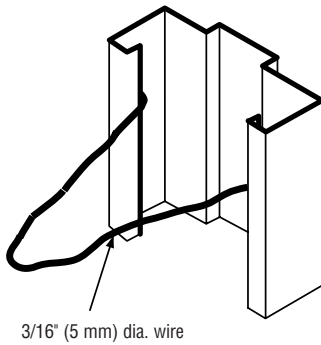

3/16" (5 mm) dia. wire

**Existing Masonry Anchor**

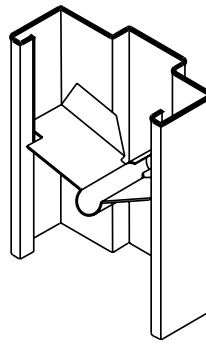

**Adjustable Base Anchor**

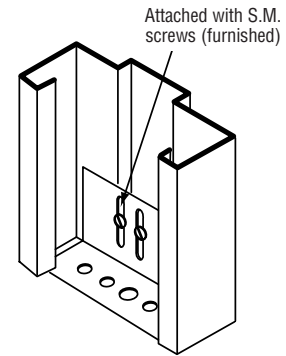

Maximum adjustment  
1-3/8" (35 mm) below frame

**Anchor for Stud Partition**

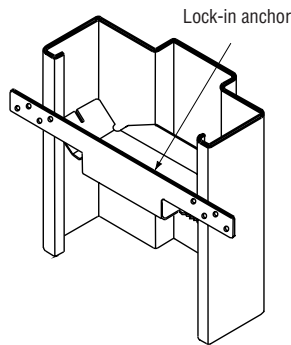

## ANCHORING AND INSTALLATION NOTES:

- MU-Series Multi-Use Flush Frames** are supplied standard with masonry wire, or lock-in jamb anchors and adjustable base anchors. Anchors are designed for maximum wall/frame engagement and installation flexibility.
- Anchoring applications:**
  - Masonry wall** – Masonry wire anchors (3/16" [5mm] dia.) provide maximum engagements in mortar joints, and allow for full internal grouting during installation. Adjustable base anchors are attached directly to the floor and adjusted. The wall is built around the anchored frame. (Refer to installation sheet #INS-2004)
  - Existing masonry walls (EMA)** – Specifically designed (18 Ga. steel) jamb anchors are used to add support for bolting the frame into the rough opening of an existing wall. An existing wall anchor is used as the base anchor in this application. (Refer to installation sheet #INS-2014)
  - Wood stud walls** – Lock-in (18 Ga. steel) jamb anchors are designed to be attached to the wood studs of a rough opening. After the frame is anchored, the wallboard is installed and finished. (Refer to installation sheet #INS-2005)

- Steel stud walls** – Lock-in (18 Ga. steel) jamb anchors are designed to be screw attached to the webbing of the closed steel studs which are built around the frame. Adjustable base anchors are attached directly to the floor and adjusted. After frame is anchored, the wallboard is installed and finished. (Refer to installation sheets #INS-2006 and 2007.)
- Installation caution notice:** When temperature conditions necessitate an additive to be used in the plaster or mortar to prevent freezing, the contractor installing the frames shall coat the inside of the frames in the field with a corrosion resistant coating per SDI 105.
  - Installation shall conform to the published Steelcraft installation instructions, SDI 105 *Recommended Installation Instructions for Steel Frames* and ANSI/DHI A115-IG *Installation Guide for Doors and Hardware*.