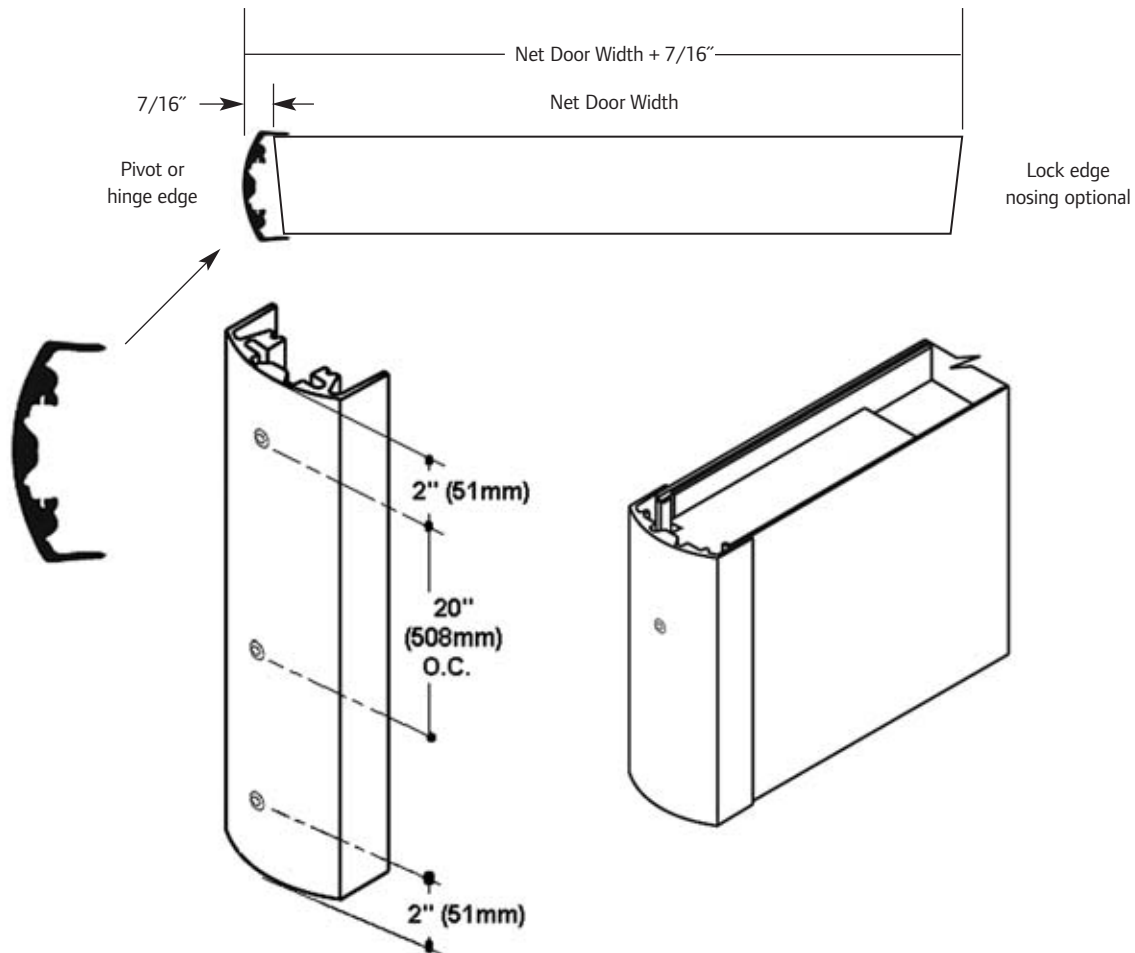

## ALUMINUM DOOR EDGE NOSING

**PURPOSE:**

Optional aluminum door edge nosing is recommended for use on double acting doors to minimize the operating clearance, between the door edge(s) and the jamb(s) of the frame.

**APPLICATION:**

- Door edge nosing, manufactured from extruded aluminum, is prime painted.
- Recommended application to hinge edge of doors equipped with Double Acting Center Hung Pivots, Double Acting Spring Hinges, Double Acting Floor Closers and Rescue Hardware to reduce the additional vertical edge clearances required.
- Some applications may require nosing to be applied to both the pivot/hinge and lock edges of the door. Door size and/or pivot/hinge location must be adjusted accordingly.
- The door edge nosing is placed over the door edge. A No.4 x 1" oval head sheet metal screw is installed through a  $3/16''$  (5mm) diameter hole to attach the unit to the door.
- Double acting doors are normally installed in cased open frames (frames that have no stops). However, smoke and fire can penetrate the clearance gap, creating a failure.
- No labeled applications.

**PRODUCT AVAILABILITY:**

This door option is available for the L, B, CE, A and AN Series doors.