

JAMB ANCHOR APPLICATIONS

Wire Anchor - Masonry Wall

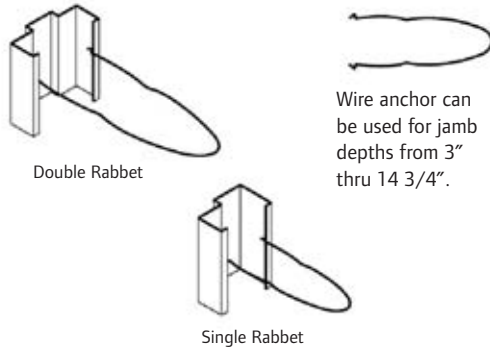

Existing Masonry Wall Anchor

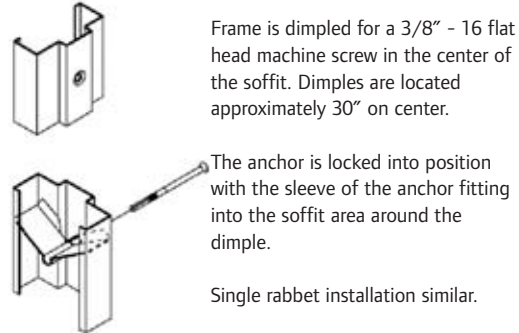

Wood or Steel Stud Anchor

Lock anchor into place as shown. Locate anchors at the top of each hinge reinforcement and the corresponding locations of the strike side.

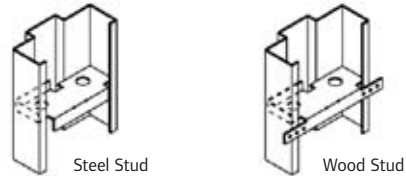

NOTES:

1. Installation shall conform to the published Steelcraft installation instructions, ANSI A250.11-2001 (formerly SDI 105) Recommended Erection Instructions for Steel Frames. Fire Rated Assemblies must be in accordance with NFPA Pamphlet 80. The AHJ is the final authority in issues related to the installation and use of installed Fire Rated Doors.
2. Wall anchors are in accordance with the Specification Sheets applicable to the frame series used.
3. Base (for vertical members) and Sill Anchors (for members along the floor), must be fastened to the floor with expansion shell, or rawl plugs and machine screws (ram-setting, shells, plugs and ram setting is by others). Adjust frame so the head is level, vertical members are plumb, and tighten the adjustable base anchors.

BASE ANCHOR APPLICATIONS

Jamb Base Anchor

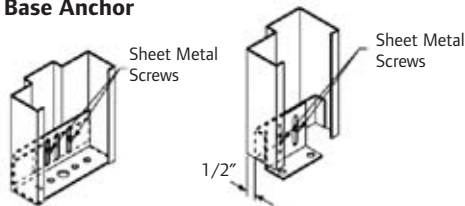

Spot or tack weld the attaching plate to and flush with the bottom of the jamb. Attach the adjustable base anchor to the attaching plate with sheet metal screws supplied with the anchor.

The anchor is fastened to the floor with expansion shields or rawl plugs and machine screws or by Ram-setting (shields, plugs and ram setting by others). Adjust frame so head is level and tighten the adjustable base anchor screws.

Mullion Base Anchor

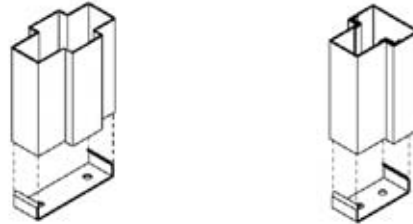

Base anchors are attached to the floor at the locations required for the mullion. Be sure anchors are located at the exact locations of the vertical mullions. The frame is raised above the anchor and then lowered down on to the floor over the anchor.

Sill Section Base Anchor

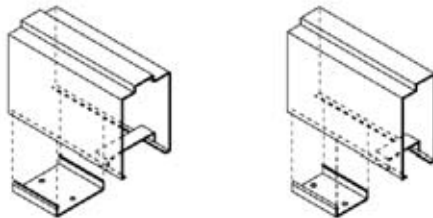

Anchors are recommended for sills that exceed 5'0" in length. Attach the anchor to the floor following directions shown for mullion base anchors.

Corner Post Anchor (2 and 3 Way Posts)

Fastening procedure same as mullion base anchor.

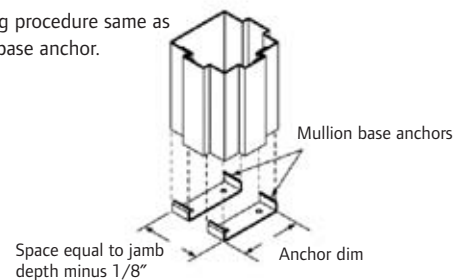

NOTES:

1. Installation shall conform to the published Steelcraft installation instructions, ANSI A250.11-2001 (formerly SDI 105) Recommended Erection Instructions for Steel Frames. Fire Rated Assemblies must be in accordance with NFPA Pamphlet 80. The AHJ is the final authority in issues related to the installation and use of installed Fire Rated Doors.
2. Wall anchors are in accordance with the Specification Sheets applicable to the frame series used.
3. Base (for vertical members) and Sill Anchors (for members along the floor), must be fastened to the floor with expansion shell, or rawl plugs and machine screws (ram-setting, shells, plugs and ram setting is by others). Adjust frame so the head is level, vertical members are plumb, and tighten the adjustable base anchors.