

PROFILE VARIATIONS DW, K & MU-SERIES FRAMES

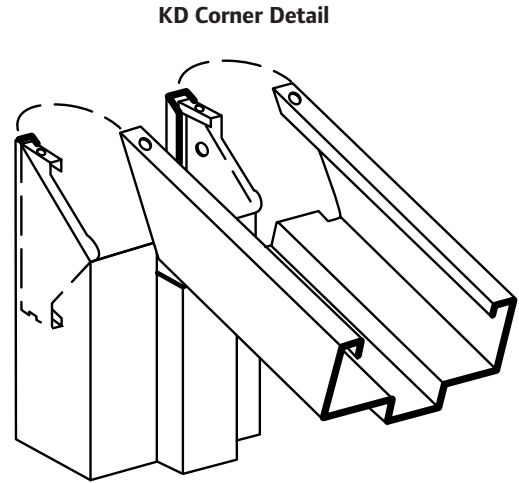
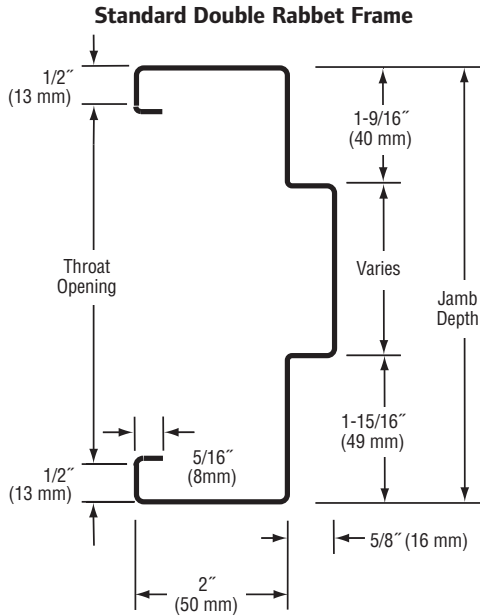

Product: DW, K & MU-Series

Gage: 16 Ga. (1.3mm), 14 Ga. (1.7mm)

Jamb Depth: DW & K = 4 1/2" (114mm) thru 14-3/4" (375mm) in 1/8" increments
 MU = 4-3/4" (114mm) thru 20" (508mm) in 1/8" increments

Face: Standard 2" (50mm)

Miter: 45° die miter with soffit tab and interlocking corner clip.

NOTES:

1. DW and K-Series are installed KD
2. MU-Series can be installed KD or welded.
3. **Equal rabbet** frames are supplied when specified or in communicating frame applications (refer to TD#2.3.15)
4. **Cased open** frames are used for double acting door or applied stop applications (refer to TD#2.3.22.
5. **Narrow double rabbet** frames are used for jamb depths below 4-1/2".

PROFILE VARIATIONS DW, K & MU-SERIES FRAMES

Standard Double Equal Rabbet Frame

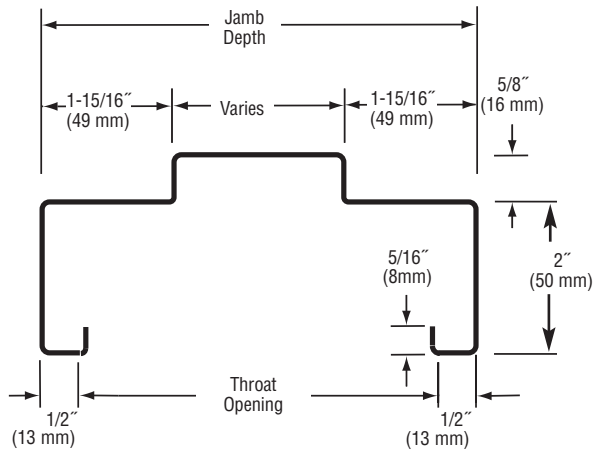

Product: DW, K & MU-Series Equal Rabbet Frames

- Gage: 16 Ga. (1.3mm), 14 Ga. (1.7mm)
- Jamb Depth: 4-7/8" (124mm) min. thru 14-3/4" (375mm) in 1/8" (3.2mm) increments
- Face: Standard 2" (50mm)
- Miter: 45° die miter with soffit tab and interlocking corner clip.

Cased Open Frame

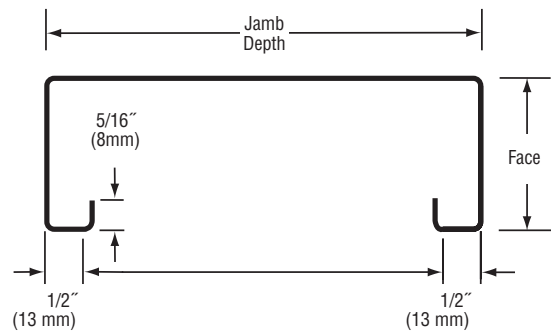

Product: DW, K & MU-Series Cased Open Frames

- Gage: 16 GA. (1.3mm), 14 Ga. (1.7mm)
- Jamb Depth: 3-1/4" (133mm) min. thru 14-3/4" (375mm) in 1/8" (3.2mm) increments
- Face: Standard 2" (50mm)
- Miter: 45° die miter with soffit tab and interlocking corner clip.

Single Rabbet Frame

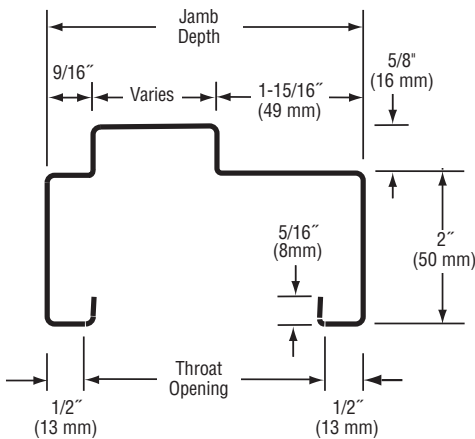

Product: DW, K & MU-Series Single Rabbet Frames

- Gage: 16 GA (1.3mm), 14 Ga. (1.7mm)
- Jamb Depth: 3-1/4" (133mm) min. thru 4 3/8" (111mm) in 1/8" (3.2mm) increments
- Face: Standard 2" (50mm)
- Miter: 45° die miter with soffit tab and interlocking corner clip.

NOTES:

1. DW and K-Series are installed KD
2. MU-Series can be installed KD or welded.
3. **Equal rabbet** frames are supplied when specified or in communicating frame applications (refer to TD#2.3.15)
4. **Cased open** frames are used double acting door or applied stop applications (refer to TD#2.3.22.
5. **Single rabbet** frames are used for jamb depths below 4 -1/2".

4" HEAD — DW, K & MU-SERIES FRAMES

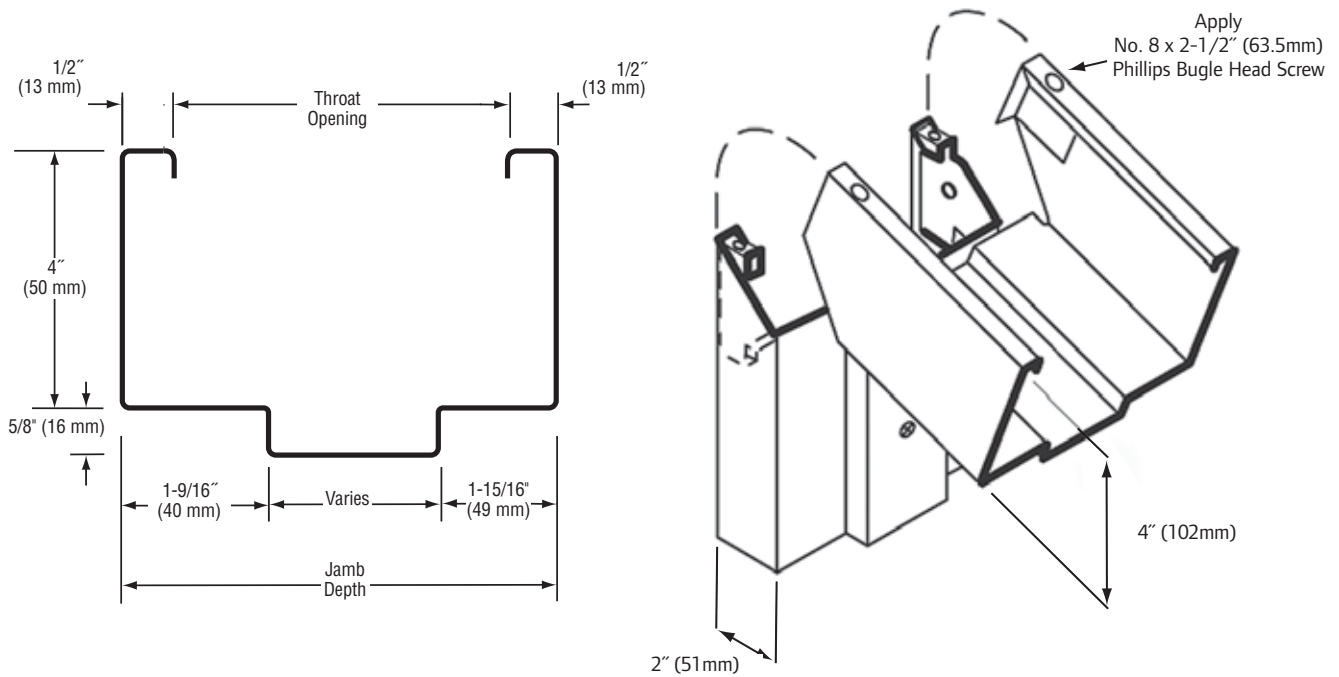

Product: DW16, DW14, K16, K14, MU16, MU14

Profile variation: Unequal, equal or single rabbet, cased open

Jamb Depth: 3-1/4" through 14-3/4" in 1/8" increments

Miter: Die mitered

NOTES:

1. MU-Series frames with 4" heads are used mainly in masonry applications when 2" face heads do not match block coursing.
2. DW and K-Series with 4" heads are used mainly, when installed in close proximity to a F-Series or MU-Series frame installed with a 4" head.

SILENCER PREPARATIONS

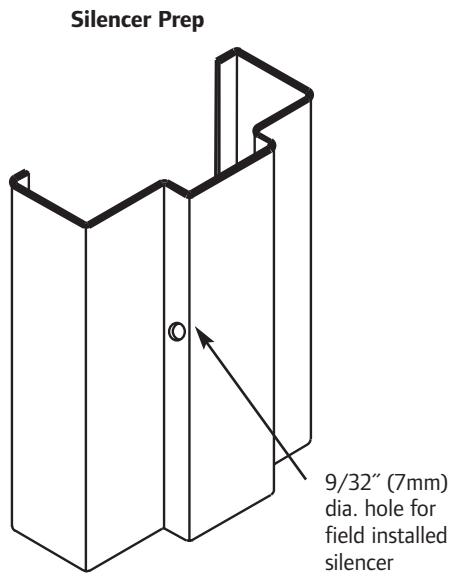

Product: Product: F, FN, FE, DE, MU, DW, & K-Series frames both open and closed sections

Description: Frames are supplied factory prepared for field installed silencers (3 per strike jamb and/or 2 per double door head).

Caution – When frames are to be grout filled, it is the responsibility of the installing contractor to guard off the silencer holes.

Exceptions – Field applied self adhesive silencers are used on all mullions.