

SURFACE CLOSER PREP

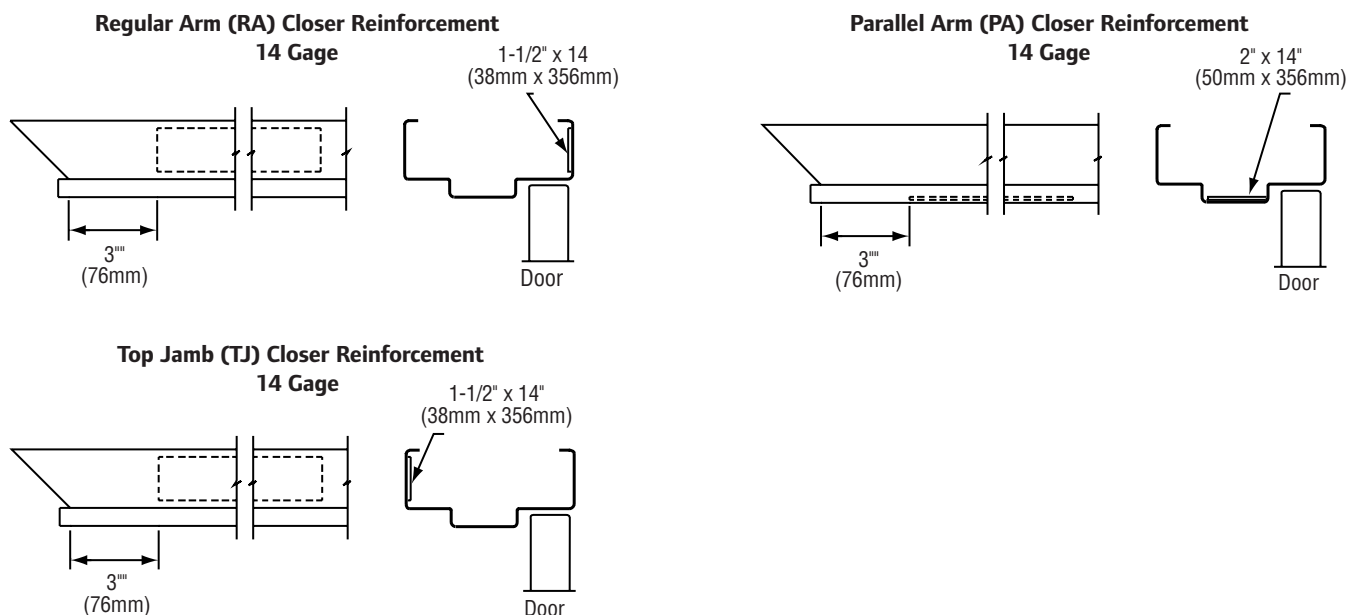

GENERAL INFORMATION:

The use of closer reinforcements allows for the surface mounting of a closer or holder on a frame. The extra material that is added to the inside of the frame head provides sufficient material for drilling and taping for the closer or holder mounting screws.

DESCRIPTION:

The reinforcement is welded to the inside face or rabbet of the frame (depends on the closer or holder mounting method).

The locations of the reinforcement for each mounting type are as follows:

- **Regular arm closers** are used on interior doors. The closer is mounted on the face of the door on the pull side of the opening. The closer arm is mounted to the face of the head member. Steelcraft identification: **RA**.
- **Parallel arm closers** are used on exterior and interior openings. The closer is mounted on the door face on the push side of the opening. The closer arm is mounted to the 1-9/16" rabbet or the soffit of the head member. Steelcraft identification: **PA**.
- **Top jamb mounted closers** are used on interior and exterior openings. The closer is mounted on the head of the frame on the non-door head face on the push side of the opening. The closer arm is mounted to the door face. Steelcraft identification: **TJ**.

The location of the individual reinforcement is such that the degree of opening or the size of the closer or holder does not affect the preparation. Reinforcements for surface mounted holders are similar to the PA mounting for a closer. The holder feet are attached to the soffit of the frame head.

REINFORCEMENT:

The reinforcement used in the frame is a 14 gage (1.7mm) steel plate 1-7/8" x 14" (48mm x 356mm) long.

SPECIFICATION COMPLIANCE:

The closer preparation in both frames and doors meets or exceed the requirements of the Steel Door Institute (SDI) and the Door and Hardware Institute (DHI).

FIRE RATINGS:

Closer reinforcements are required in all fire rated products. If the reinforcement is omitted, a special marking is required (see Fire Rated Section for information).

NOTES: 1. Frames are not supplied with the closer or holder.